



SMITH SYSTEM

Furniture for inspired learning.

Library Carrel Adders

(Adder Unit) See Instruction Sheet 179873 for Starter Unit.

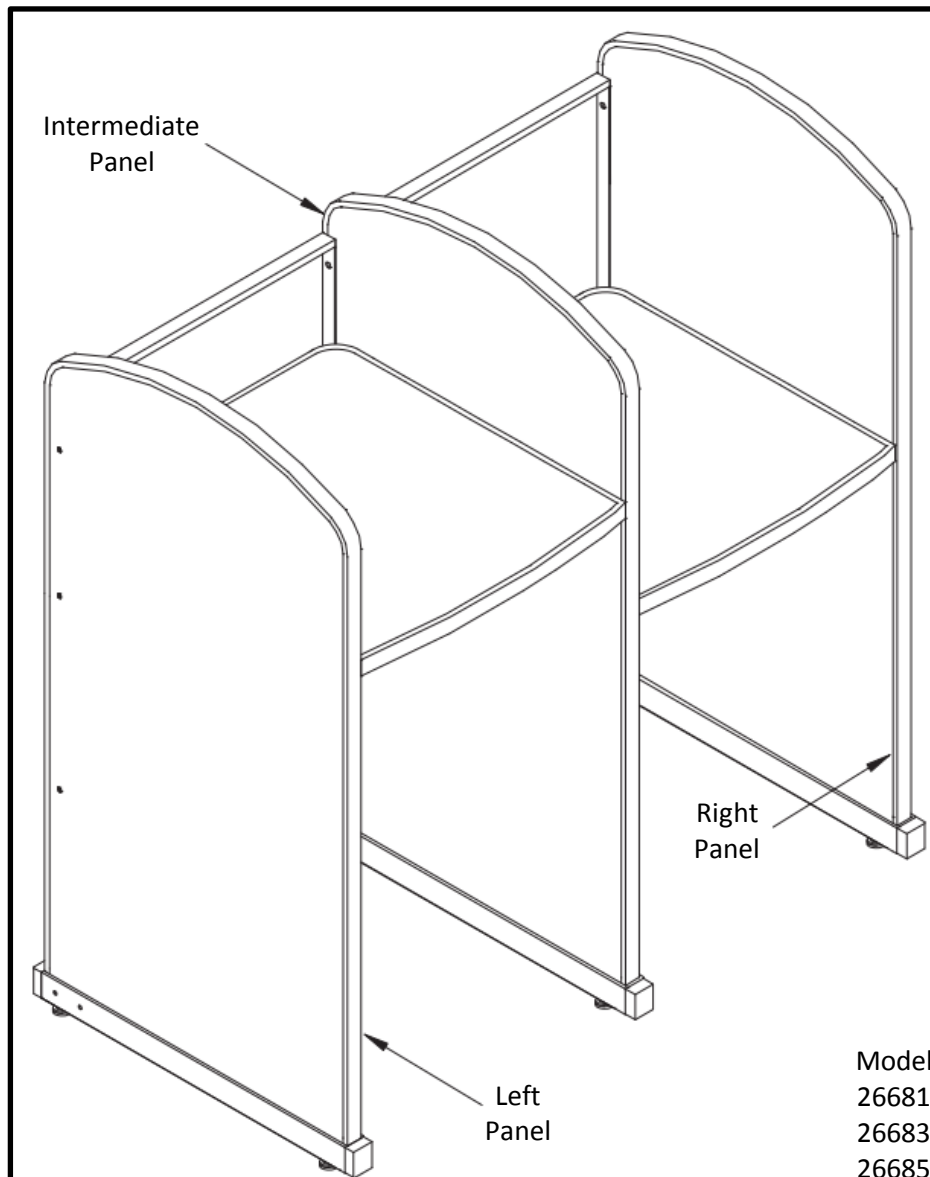

For assistance in assembling product, or to place an order please contact customer service at

Special Notes:

1. Check that all components are accounted for and undamaged before assembling.
2. Assemble the product in a clean and dry area.
3. For larger units you may need another person to help assemble the product.
4. Clean the product with a mild cleaner and a damp cloth.

Tools:

You will need a Phillips Head Screwdriver.

Hardware and Components



#10 Wood Screws
(Qty. 12)
P/N-70080

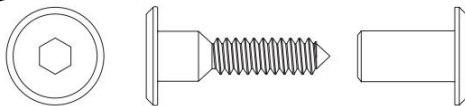

Connector Bolts (Qty. 3)
P/N-70869- Connector Bolt 1/4-20X17mm
P/N-70870 Connector Nut 1/4-20X23mm



Phillips Head Machine Screws
(Qty. 4)
P/N-70226



Allen Wrench
(Qty. 2)
P/N-77813

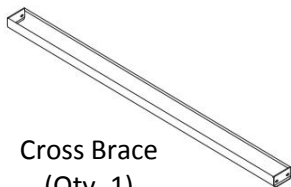

Cross Brace
(Qty. 1)

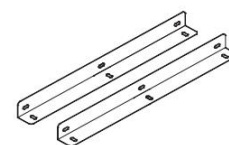

Brackets (Qty. 2)

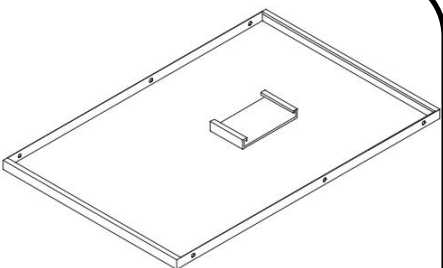

Back Panel (Qty. 1)

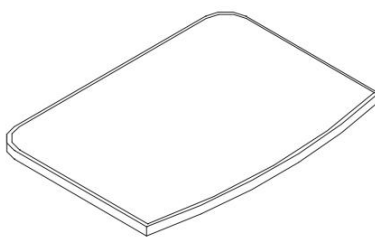

Top (Qty. 1)

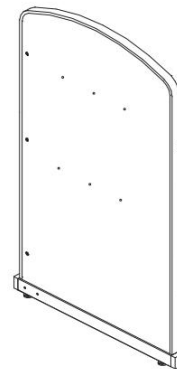

Intermediate Panel
(Qty. 1)
(Predrilled on both sides)

Replacement Pack 74125 Includes

- (12) 70080- 10x5/8 Truss Head Phillips Head
- (6) 70869- Connector Nut 1/4-20X17mm
- (6) 70870- Connector Bolt 1/4-20X23mm
- (4) 70226- Machine Screw 10-32X.5
- (2) 77813- Hex Key- 3/16" Short Arm

For assistance in assembling product, or to place
an order please contact customer service at

Assembly Instructions

Library Carrels (Starter Unit)

Urgent: Back panel orientation determines the top height. By rotating 180 degrees you can change the carrel to the desk height or the kiosk height.

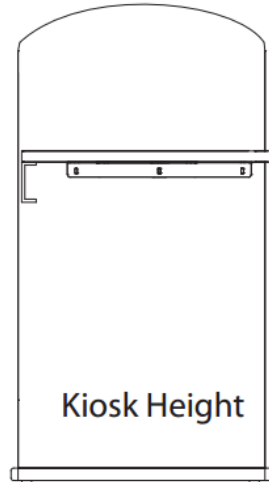
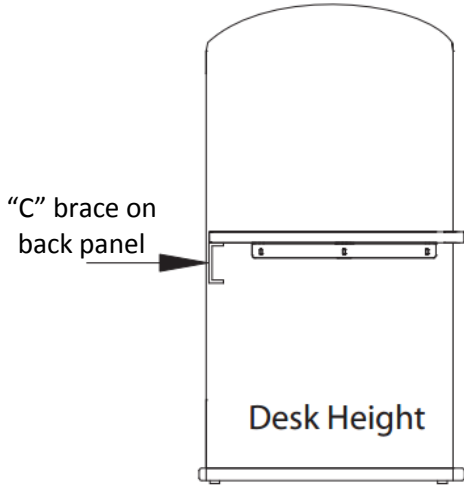

*Due to size, we recommend that two people should be involved in assembling this product.

Important Information: The starter unit comes with a left and a right panel (See Drawing 1). Before assembling our adder units, choose the side that the adder will be on. When assembling the adder, the right or left starter panels will be replaced (depending on which side you choose) with the intermediate panel (See Drawing 2).

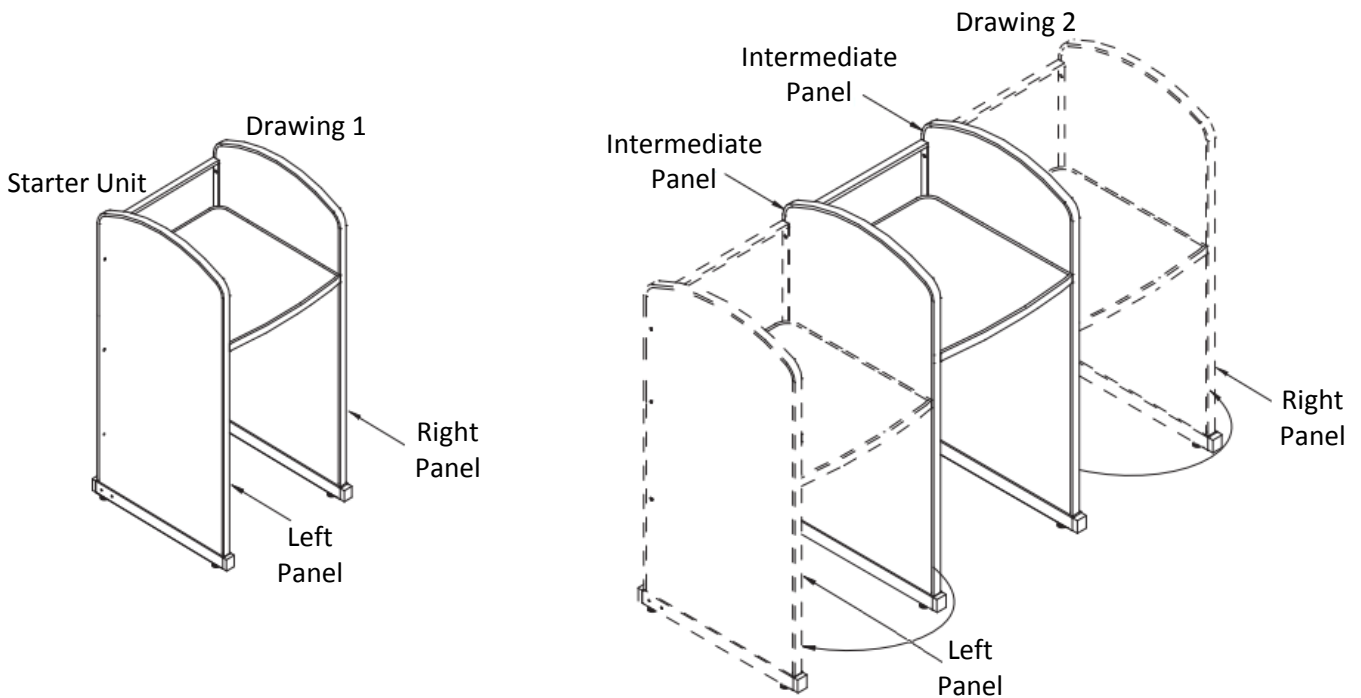

For assistance in assembling product, or to place an order please contact customer service at

Step 1: Lay the starter unit on the floor; disconnect the connector bolts from the side panel by using the "L" wrench (See Drawing 1A). Next, detach the machine screws from the cross brace; finally remove the 3 wood screws that connect the bracket to the side panel.

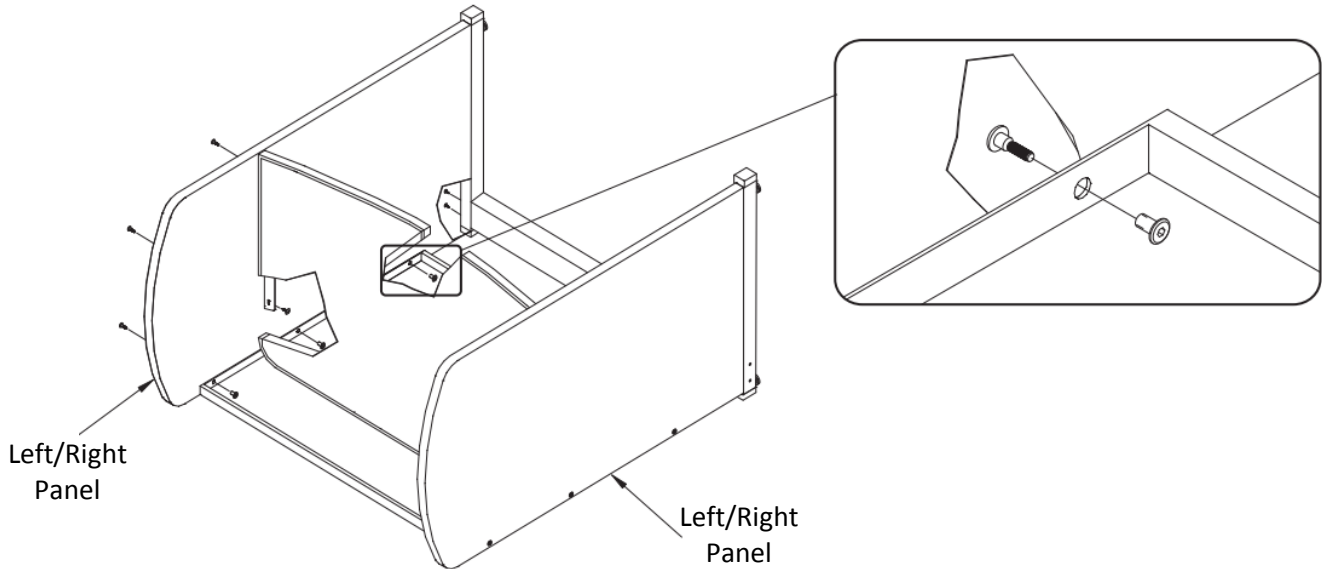

Step 2: With help, lay the intermediate panel on the floor while aligning the cross bar with the pilot holes. Attach together by using (2) Phillips head machine screws. Next, attach the bracket, located underneath the top, to the intermediate panel by using (3) wood screws. Lay the second back panel, with the bracket facing up, on the other side of the intermediate panel. Verify alignment with the pilot holes and attach using (3) connector bolts.

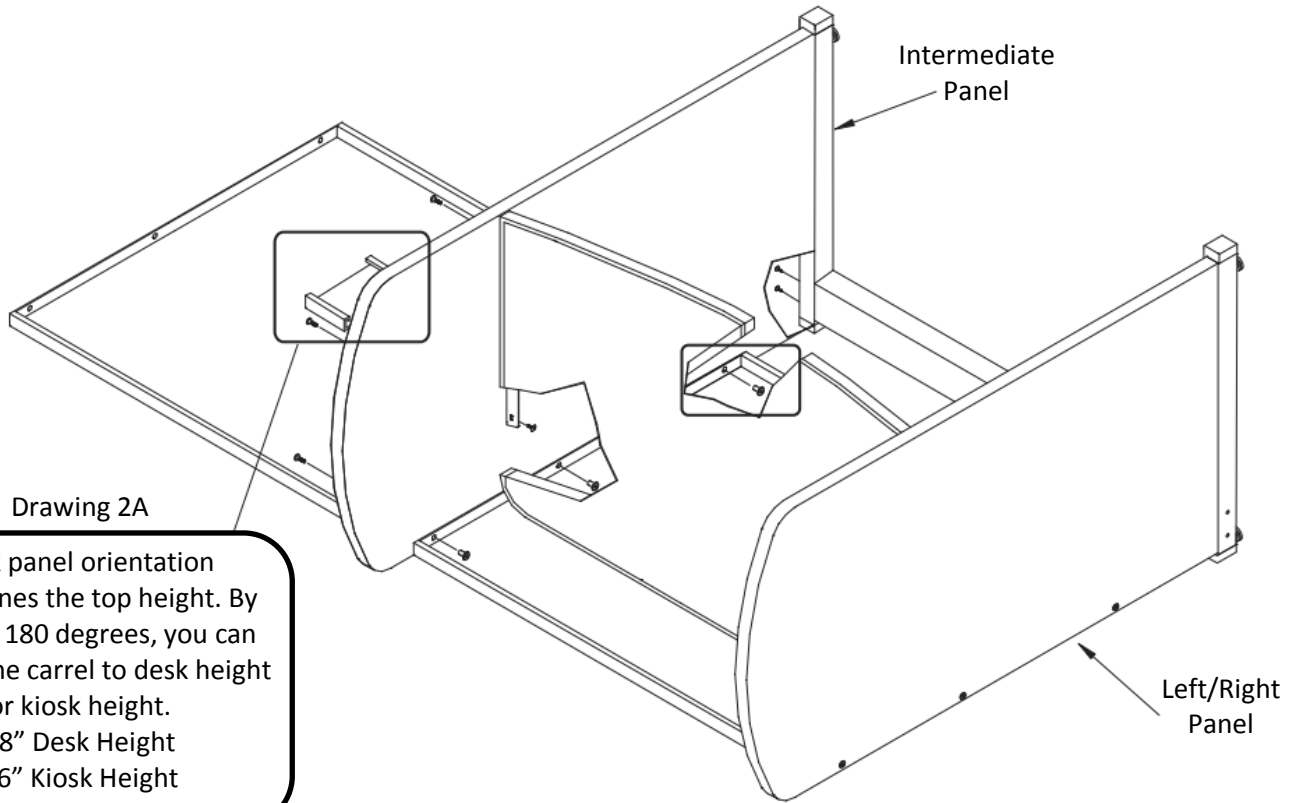

Drawing 2A
 Back panel orientation determines the top height. By rotating 180 degrees, you can change the carrel to desk height or kiosk height.
 28" Desk Height
 36" Kiosk Height

For assistance in assembling product, or to place an order please contact customer service at

Step 3: With help, lay the side panel on the floor while aligning the cross bar with the pilot hole. Attach together by using (2) Machine Screws (See Drawing 3A).

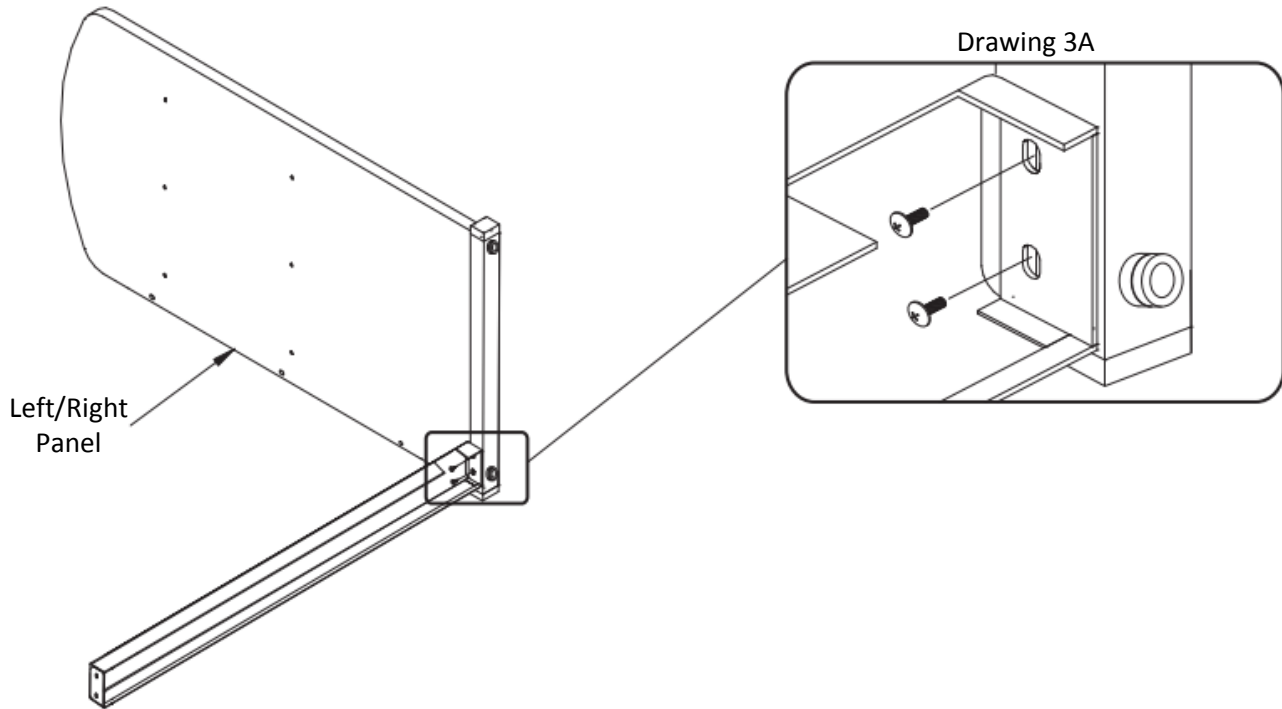

Step 4: Lay the adder unit on the floor and align the cross bar with the (2) pilot holes. Attach together by using (2) machine screws. Next, attach the back panel with the adder unit by using (3) connector bolts. Next, attach the brackets to either kiosk or desk height by using (6) wood screws.

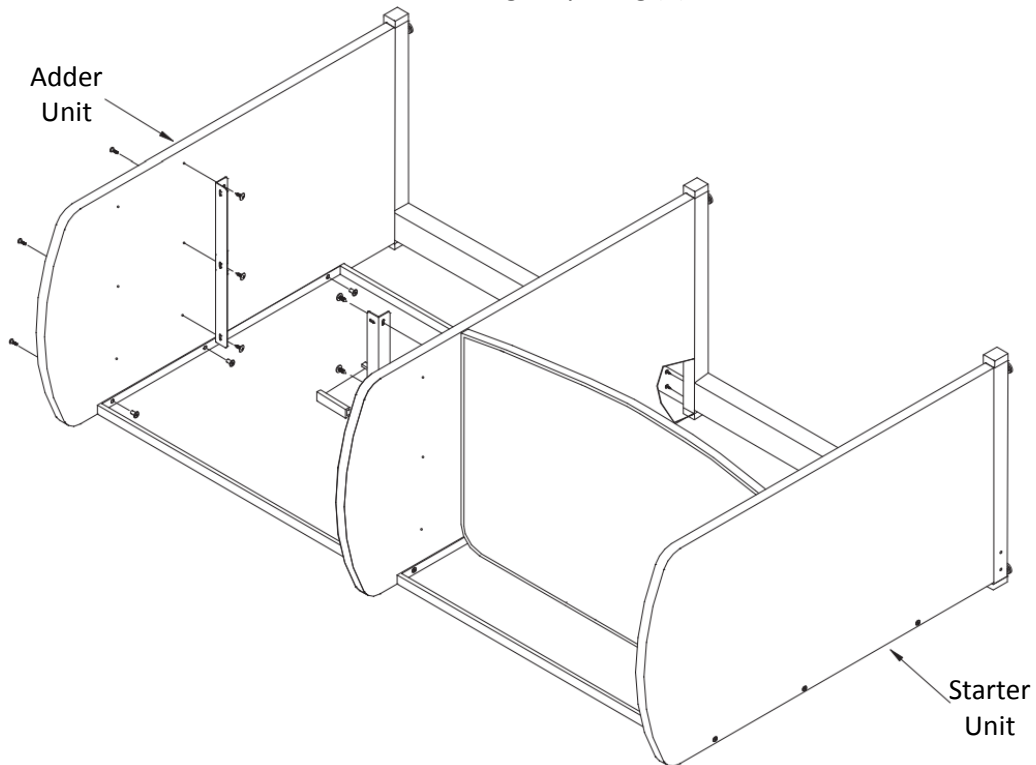

For assistance in assembling product, or to place an order please contact customer service at

Step 5: With help, se the unit upright on its feet and slide the work surface above both brackets until it runs flush against the back panel. Align the predrilled holes underneath the table top with the brackets. Using (6) wood screws, attach the top to the brackets (See Drawing 5A).

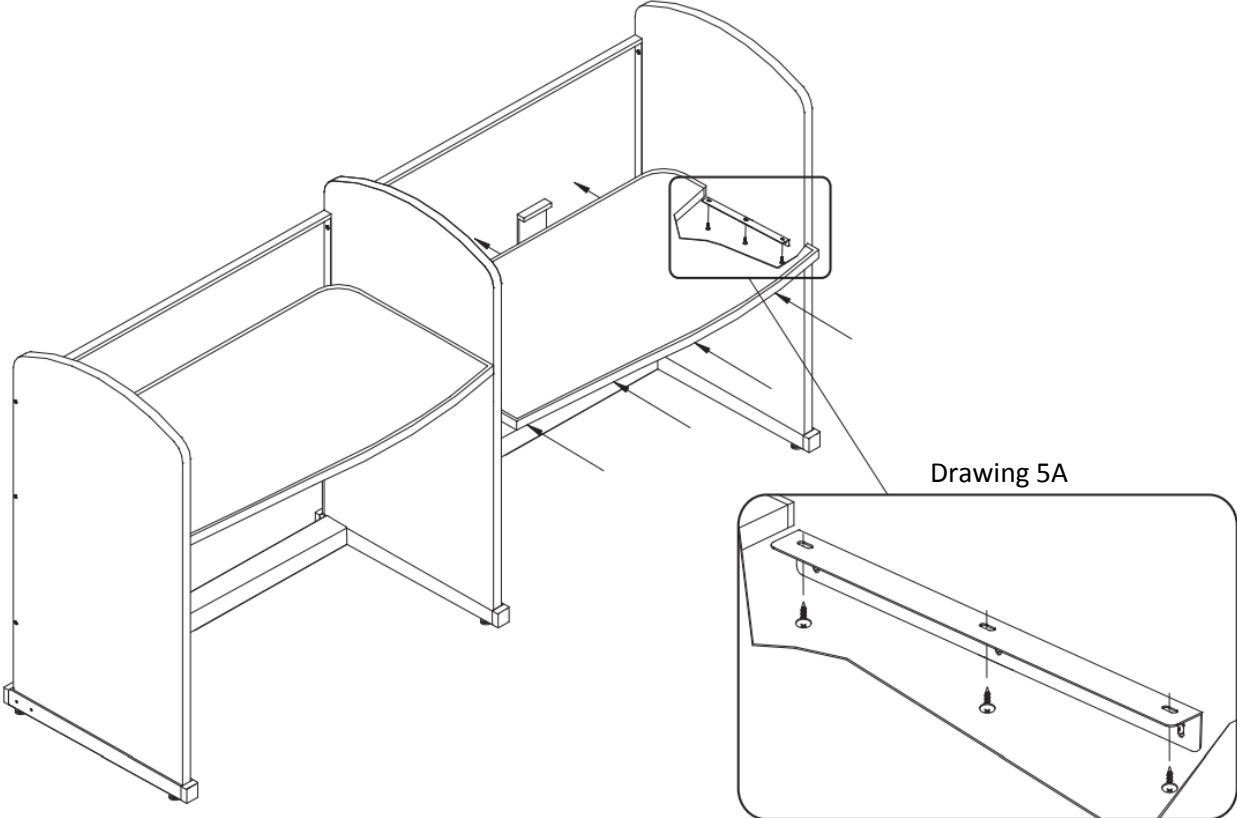

For assistance in assembling product, or to place an order please contact customer service at