

assembly instructions

interchange wing

- check that all components are accounted for and undamaged before assembly.
- assemble product in a clean, dry area; if cleaning is necessary, use a mild cleaner and damp cloth.
- for larger units, a second person is recommended for assistance in the assembly process.

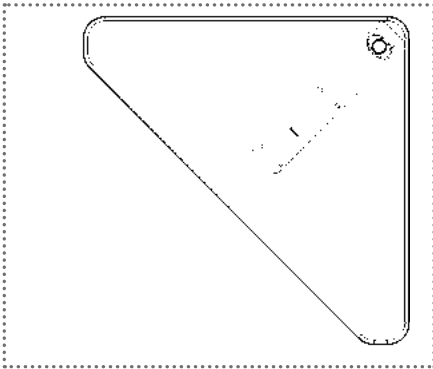

1. align center support brace with pre-drills in top.

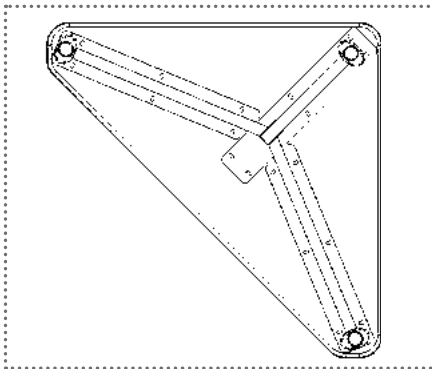
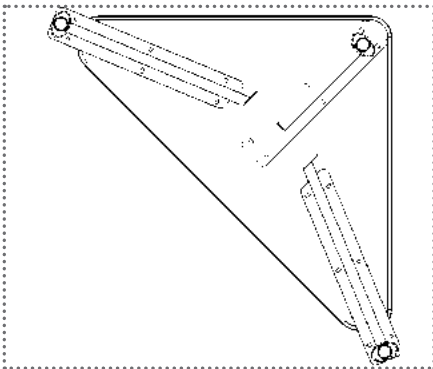

2. position the other two legs as shown and align with their respective pre-drills in the top.
3. secure the three legs together loosely with the connector bolt provided, using the included Allen Key.
4. fasten the frame assembly to the top using the wood screws provided.

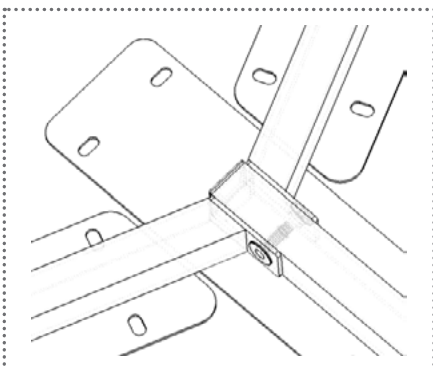

5. after the frame assembly is secured to the top, completely tighten the connector bolt with the Allen Key provided.